

REZNOR[®]**MODEL X****INDOOR, GAS-FIRED, GRAVITY-VENTED
DUCT FURNACE FOR COMMERCIAL/
INDUSTRIAL USE**

ANSI Z83.8a



CGA 2.6a

**STANDARD FEATURES**

- Orifices for natural gas
- Aluminized steel heat exchanger
- Aluminized steel burners with stainless steel insert
- 120-volt supply voltage
- 24 volt control voltage transformer
- High limit safety cutout
- Single-stage combination gas valve (see note 1)
- Side access for burners and controls (left side facing air stream)
- Horizontal or vertical flue discharge
- Manual match-lit pilot (see page 18)
- Energy cutoff (ECO) device
- Blocked vent shut-off system

OPTIONAL FEATURES - FACTORY INSTALLED

- Unit equipped for propane gas
- E-3 (409) stainless steel heat exchanger (see note 2)
- 321 stainless steel heat exchanger (see note 2)
- E-3 (409) stainless steel burners (see note 2)
- E-3 (409) stainless steel drip pan (see note 2)
- Spark-ignited intermittent safety pilot with electronic flame supervision (see page 18)
- Spark-ignited intermittent safety pilot with electronic flame supervision and timed lockout (see page 18)
- Two-stage controls (see page 18-19)
- Electronic modulation - 50%-100% firing rate (see page 18-19)
- Mechanical modulation (see page 18-19)
- Burner air shutters (required on units equipped with propane gas)
- Fan control (see page 19)
- Terminal blocks for connecting field wiring
- 208/230/460-volt alternate supply voltage
- Right side controls (facing airstream)

OPTIONAL FEATURES - FIELD INSTALLED

- Single-stage thermostat
- Two-stage thermostat
- Electronic room override (makeup air applications only)
- Thermostat guard with locking cover
- Manual shut-off valve and union
- Power venter with venter adapter (see page 15)
- Condensate drain flange kit
- Disconnect switch (UL Listed)

DESCRIPTION

Reznor X Series Duct Furnaces are designed to provide **80% thermal efficiency** for indoor application with gravity venting. They are certified for use with natural or propane gas, as specified, in sizes from 75,000 through 400,000 BTUH input. These models are used as heating components in heating, heating/cooling, or makeup air systems and require a separate blower system for air delivery. The furnace has a Reznor Thermocore[®] aluminized steel heat exchanger with venturi-design tubes. The die-formed burners are of aluminized steel and include flared ports with a stainless steel insert.

The Model X furnace is approved for a temperature rise range of 50°F to 90°F and includes “finger-baffles” for proper air distribution at these lower air volumes. The HX Model does not include finger baffles and is approved for a temperature rise range of 20°F to 75°F.

Standard features include a manual match-lit pilot and a single-stage, 24-volt gas valve. Model X/HX units are wired for field connection to a remote 24-volt thermostat for automatic operation. Each unit is provided with all required limit and safety controls, including an energy cutoff (ECO) and a blocked vent shut-off system.

NOTES:

1. Regulated combination redundant gas valve consists of combination pilot solenoid valve, electric gas valve, pilot filter, pressure regulator, pilot shut-off, and manual shut-off, all in one body. Gas supply pressure must not exceed 0.5 PSI (8 oz. - 14 “ W.C.). Minimum inlet pressure for natural gas is 5” W.C. Minimum inlet pressure for propane gas is 11” W.C.
2. For air inlet temperatures below 40°F or temperature rise less than 40°F, an optional stainless steel heat exchanger is recommended (see page 22).
3. See page 20 for temperature rise and pressure drop tables.
4. Blower must be placed on entering side of furnace.
5. Approved for installation downstream of an air conditioning coil (optional drain flange, stainless steel heat exchanger, and stainless steel burners are recommended).
6. **Not** approved for residential use.

MODEL X

INDOOR, GAS-FIRED, GRAVITY-VENTED DUCT FURNACE FOR COMMERCIAL/INDUSTRIAL USE

Technical Data

Size		75	100	125	150	175	200	225	250	300	350	400
Input Heating Capacity	BTUH	75,000	100,000	125,000	150,000	175,000	200,000	225,000	250,000	300,000	350,000	400,000
	kW	22.0	29.3	36.6	44.0	51.3	58.6	65.9	73.3	87.9	102.6	117.2
Output Heating Capacity (80%) ^A	BTUH	60,000	80,000	100,000	120,000	140,000	160,000	180,000	200,000	240,000	280,000	320,000
	kW	17.6	23.4	29.3	35.2	41.0	46.9	52.8	58.6	70.3	82.1	93.8
Full Load Amps (115V)		0.2	0.2	0.2	0.2	0.2	0.2	0.2	0.2	0.2	0.2	0.2
Unit Control Amps (24V)		0.3	0.3	0.3	0.3	0.3	0.3	0.3	0.3	0.3	0.3	0.3
X Air Volume	cfm	610-1,105	815-1,475	1,020-1,840	1,225-2,210	1,430-2,580	1,635-2,945	1,840-3,315	2,045-3,685	2,455-4,420	2,865-5,160	3,275-5,895
	m ³ /hr	1,036-1,877	1,385-2,506	1,733-3,126	2,081-3,755	2,429-4,383	2,778-5,003	3,126-5,632	3,474-6,261	4,171-7,509	4,867-8,767	5,564-10,015
HX Air Volume	cfm	735-2,765	980-3,685	1,225-4,605	1,475-5,530	1,720-6,450	1,965-7,370	2,210-8,295	2,455-9,215	2,945-11,060	3,440-12,900	3,930-14,745
	m ³ /hr	1,249-4,698	1,665-6,261	2,081-7,824	2,506-9,395	2,922-10,958	3,338-12,521	3,755-14,093	4,171-15,656	5,003-18,790	5,844-21,916	6,677-25,051
Net Weight	lbs	150	150	163	182	186	224	231	276	286	320	355
	kg	68	68	74	83	84	102	105	125	130	145	161
Ship Weight	lbs	170	170	200	220	230	275	290	350	360	390	420
	kg	77	77	91	100	104	125	132	159	163	177	191
Gas Connection (in.) Natural ^C		1/2"	1/2"	1/2"	1/2"	1/2"	1/2"	1/2"	1/2"	3/4"	3/4"	3/4"
Flue Size		5" Rd.	6" Rd.	7" Ov.	8" Ov.	8" Ov.	8" Rd.	8" Rd.	10" Ov.	10" Ov.	12" Ov.	12" Ov.

^A In U.S. ratings are for altitudes to 2,000 feet. Above 2,000 feet derate by orifice change, 4% for each 1,000 feet above sea level.

In Canada ratings are for altitudes to 2,000 feet. For high altitude units (2,001-4,500 ft.) derate by 10% of maximum input.

^B Prefix "H" indicates high CFM units without finger baffles.

^C Sizes shown are for natural gas connections and are applicable to single stage gas valves, NOT supply line size. Propane gas connection is 1/2" for all sizes.

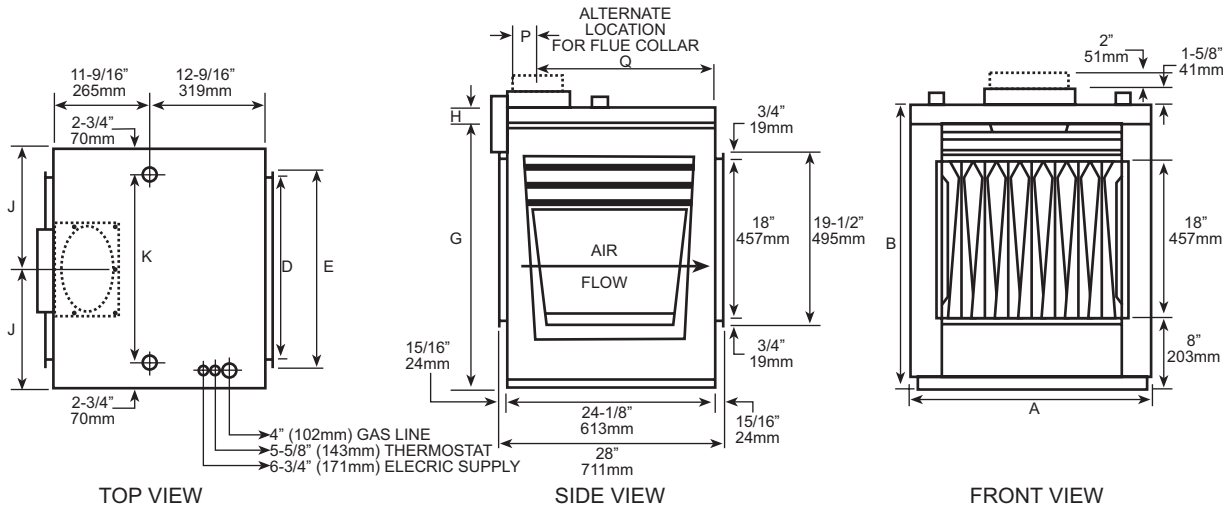

Dimensions ±1/8" (3mm)

SIZE	A		B		D		E		G		H		J		K		P		Q	
	in.	mm	in.	mm	in.	mm	in.	mm	in.	mm	in.	mm	in.	mm	in.	mm	in.	mm	in.	mm
75	19 1/4	489	32 1/4	819	12 1/2	318	14	356	30 1/4	768	2	51	9 5/8	244	13 3/4	349	3 1/2	89	20 3/4	527
100	19 1/4	489	32 1/4	819	12 1/2	318	14	356	30 1/4	768	2	51	9 5/8	244	13 3/4	349	3 1/2	89	20 3/4	527
125	22	559	32 1/4	819	15 1/4	387	16 3/4	425	30 1/4	768	2	51	11	279	16 1/2	419	3 1/2	89	20 3/4	527
150, 175	27 1/2	699	32 1/4	819	20 3/4	527	22 1/4	565	30 1/4	768	2	51	13 3/4	349	22	559	3 1/2	89	20 3/4	527
200, 225	33	838	35 1/4	895	26 1/4	667	27 3/4	705	31 3/4	806	3 1/2	89	16 1/2	419	27 1/2	699	5	127	19 1/4	489
250, 300	41 1/4	1,048	35 1/4	895	34 1/2	876	36	914	31 3/4	806	3 1/2	89	20 5/8	524	35 3/4	908	5	127	19 1/4	489
350	46 3/4	1,187	35 1/4	895	40	1,016	41 1/2	1,054	31 3/4	806	3 1/2	89	23 3/8	594	41 1/4	1,048	5	127	19 1/4	489
400	52 1/4	1,327	35 1/4	895	45 1/2	1,156	47	1,194	31 3/4	806	3 1/2	89	26 1/8	664	46 3/4	1,187	5	127	19 1/4	489

NOTES

1. Burner and control access shown left hand side. Specify right hand for opposite access and connections (Option AJ2).
2. Standard air flow as shown. Direction of air flow may be reversed by field relocation of air baffles.
3. For power venting arrangement, see page 15.

CLEARANCE FROM COMBUSTIBLES

1. Top, flue connections, side opposite controls - 6"
2. Control side - unit width plus 6"
3. Bottom - 3"