



Gas Conversion Kits and Instructions

REZNOR *Thomas & Betts*

INSTALLATION FORM RGM 432/433-GC (Version D)
Obsoletes Form RGM 432/433-GC (Version C)

APPLIES TO: Model FT and Model SFT

All gas conversion must be done by a qualified service person in accordance with these instructions and in compliance with all codes and requirements. In Canada, gas conversion shall be carried out in accordance with the requirements of the Provincial Authorities having jurisdiction and in accordance with the requirements of the CAN/CGA-B149.1 and .2 installation code.

WARNING: Improper installation, adjustment, alteration, service, or maintenance can cause property damage, injury, or death. For assistance or additional information, consult a qualified installer, service agency, or the gas supplier.

FOR YOUR SAFETY

What to do if you smell gas:

- Do not try to light any appliance.
- Do not touch any electrical switch; do not use any phone in your building.
- Immediately call your gas supplier from a neighbor's phone. Follow the gas supplier's instructions.
- If you cannot reach your gas supplier, call your fire department.

FOR YOUR SAFETY

Do not store or use gasoline or other flammable vapors and liquids in the vicinity of this or any other appliance.

DANGER: The conversion kit is to be selected and installed by a qualified service person in accordance with these instructions and in compliance with all codes and requirements of authorities having jurisdiction. Failure to follow instructions could result in death, serious injury and/or property damage. The qualified agency performing this work assumes responsibility for this conversion.

HAZARD INTENSITY LEVELS

1. **DANGER:** Failure to comply will result in severe personal injury or death and/or property damage.
2. **WARNING:** Failure to comply could result in severe personal injury or death and/or property damage.
3. **CAUTION:** Failure to comply could result in minor personal injury and/or property damage.

Application and Kit Selection

The gas conversion kits in these instructions are for Model FT and Model SFT heaters equipped with a **single-stage valve**. See pages 6 and 7 for conversion kit components.

Be sure that the kit selected applies to the model and size being converted.

DANGER: The gas burner in this gas-fired equipment is designed and equipped to provide safe and economically controlled complete combustion. However, if the installation does not permit the burner to receive the proper supply of combustion air, complete combustion may not occur. The result is incomplete combustion which produces carbon monoxide, a poisonous gas that can cause death.

Safe operation of indirect-fired gas burning equipment requires a properly operating vent system which vents all flue products to the outside atmosphere. FAILURE TO PROVIDE PROPER VENTING WILL RESULT IN A HEALTH HAZARD WHICH COULD CAUSE SERIOUS PERSONAL INJURY OR DEATH.

On separated combustion Model SFT heaters, install either the horizontal or vertical combustion air/vent system illustrated in the heater installation manual, using the concentric adapter supplied. For installations of either Model FT or Model SFT, always comply with the combustion air requirements in the installation codes and instructions. Model FT units installed in a confined space must be supplied with air for combustion as required by Code and in the heater installation manual. Combustion air at the burner should be regulated only by manufacturer-provided equipment. **NEVER RESTRICT OR OTHERWISE ALTER THE SUPPLY OF COMBUSTION AIR TO ANY HEATER. MAINTAIN THE VENT SYSTEM IN PROPERLY OPERATING CONDITION.**

Gas Conversion Instructions

1. Check kit contents for agreement with the parts list. A parts list for each kit is on pages 5-6.

The kits listed in this manual are intended for use on units that will be operated at sea level. Conversion of a unit using these kits will not alter the input rate. Refer to the rating plate on the heater for input rate and other appropriate information.

2. Turn off the gas supply at a shutoff valve upstream of the combination valve and turn off the electrical supply. Open the control access panel.

3. Select and Install the Regulator Spring Kit (valve conversion kit)

Depending on the size and gas type, there will be one or two regulator spring kits in the gas conversion kit. The manufacturer of the regulator spring kit must be the same as the manufacturer of the gas valve. Look at the gas valve and make note of the name of the manufacturer.

If there are two regulator spring kits in the gas conversion kit, select the one whose manufacturer matches the name on the gas valve.

If there is only one regulator spring kit, verify to be sure that the names match. If the names of the manufacturers do not match, do not install the spring regulator kit. Contact your distributor to determine the correct spring regulator kit.

To install the spring regulator conversion kit, follow the valve manufacturer's installation instructions that are included with the kit. After a new regulator spring kit is installed, it is necessary to adjust the spring for the correct manifold pressure. This adjustment can only be made after the heater is in operation. Instructions are included in Step No. 8.

WARNING: Manufacturer of regulator spring kit and gas valve must be the same. Spring kits of different manufacturers are not interchangeable, and each spring kit must be used only in the valve for which the kit is designated.

WARNING: The operating valve is the primary safety shutoff. The gas supply line must be free of dirt or scale before connecting the unit.

4. Install Burner Orifices

WARNING: Do not attempt to drill orifices. Use factory-supplied orifices only.

(NOTES: Kits that apply to various sizes of heaters include the quantity of burner orifices required for the largest size of heater. When converting the smaller sizes, there will be extra burner orifices which will not be used.)

MODEL FT Instructions (See Figure 1)

Remove the screws that retain the manifold and control assembly (See Figure 1). With the manifold and control assembly removed from the heater, unscrew all of the existing orifices and replace with the orifices included in the conversion kit.

MODEL SFT Instructions (See Figures 2 and 3)

a) Remove the Manifold

Disconnect the union on the outside of the unit and remove the gas pipe from the inlet of the gas valve.

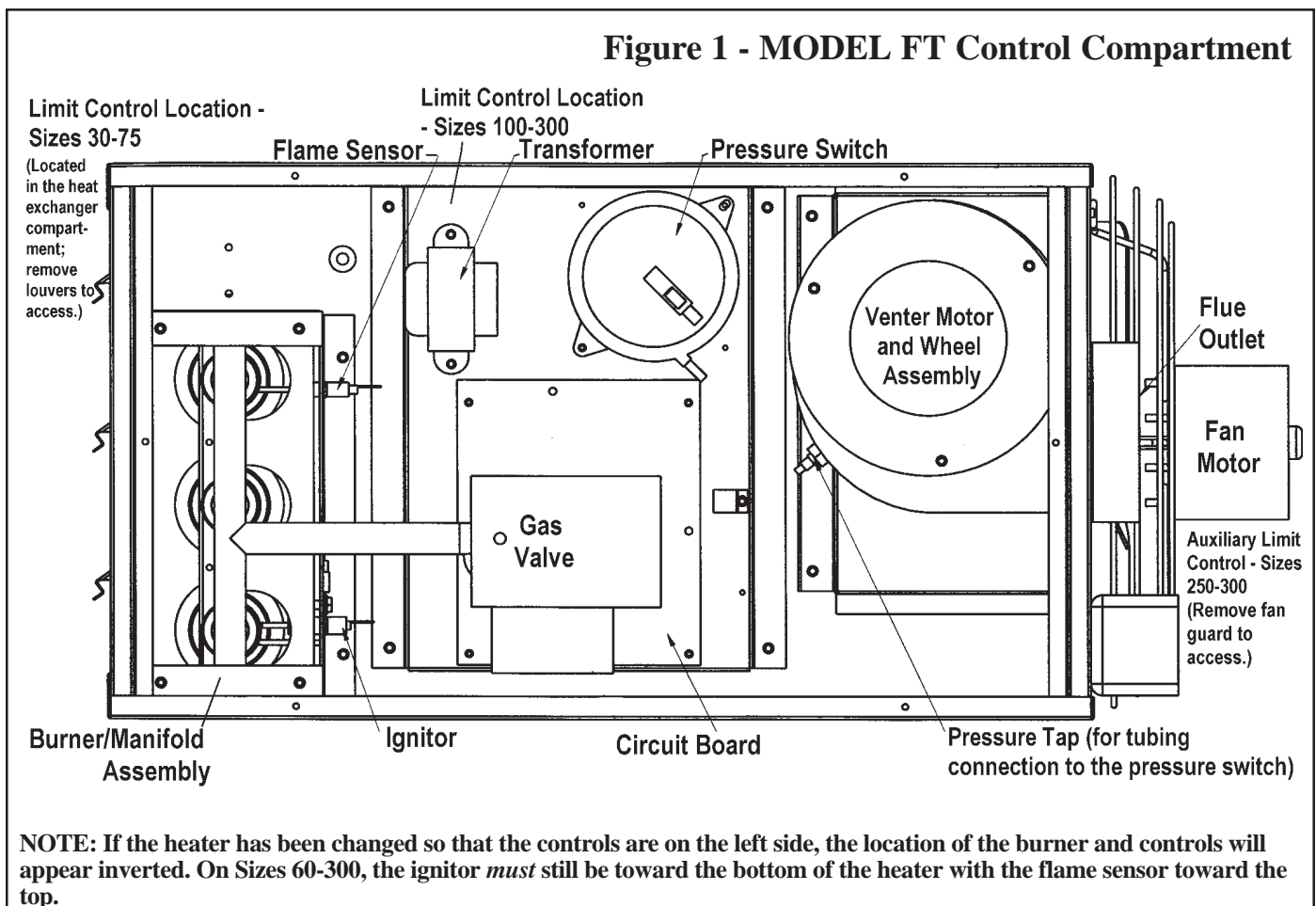

On the burner box end of the flexible hose, loosen the hose clamp. Slide the hose off the collar.

Disconnect the silicone tubing from the static tap on the burner box cover.

Remove the manifold seal plate and manifold cover plate. Remove the burner box cover. The manifold and burner rack assembly are visible.

Locate the screws that attach the manifold to the burner rack assembly. Remove the screws and slide the manifold out of the heater.

b) Change Orifices

Unscrew all of the existing orifices and replace with the orifices included in the conversion kit.

Figure 2 - MODEL SFT Control Compartment

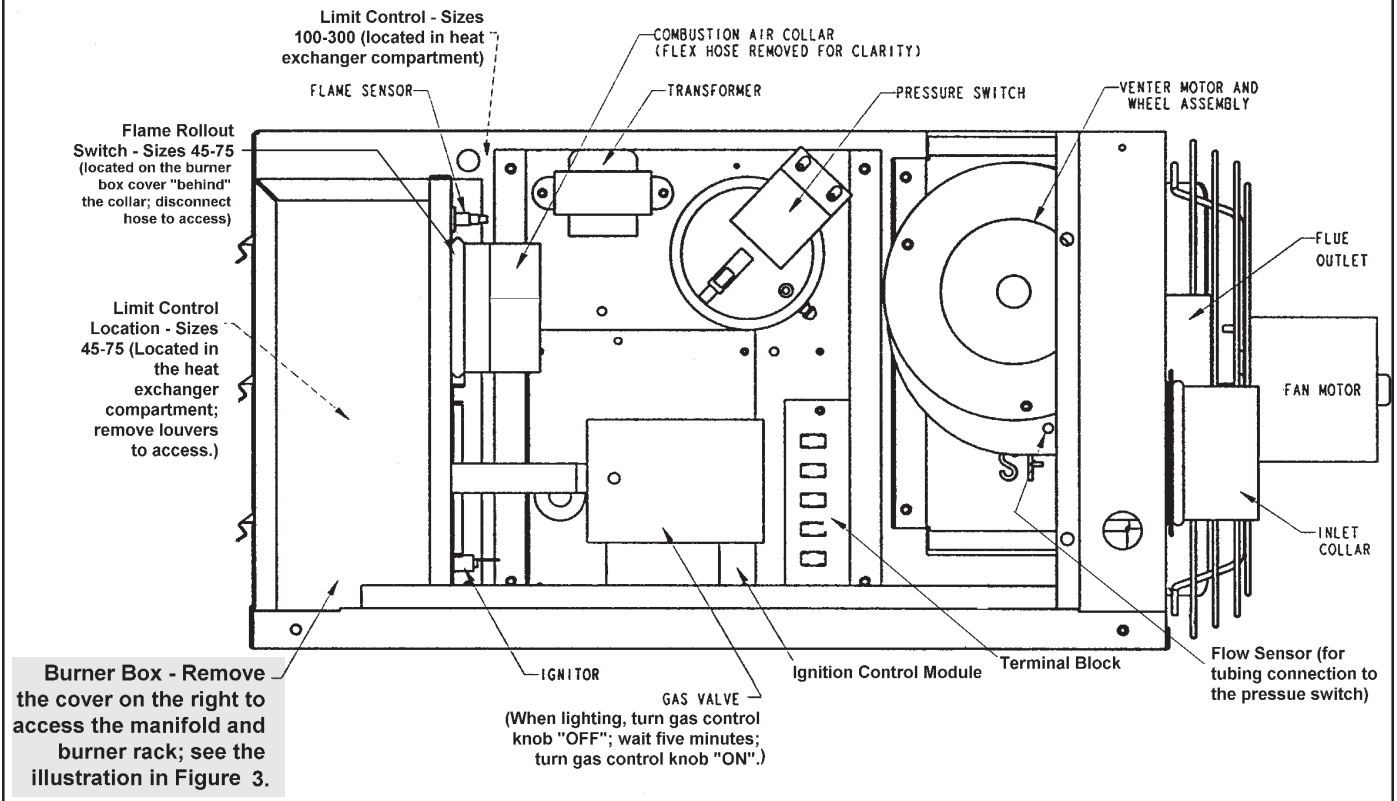
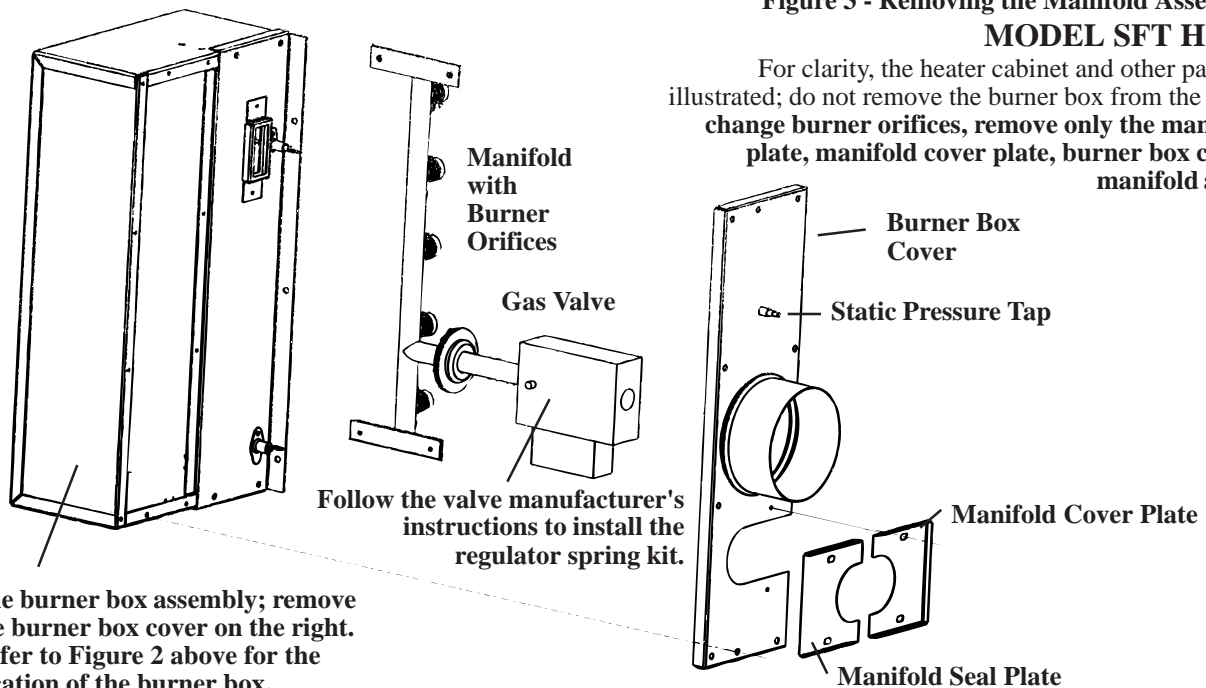

Figure 3 - Removing the Manifold Assembly of a MODEL SFT HEATER

For clarity, the heater cabinet and other parts are not illustrated; do not remove the burner box from the heater. To change burner orifices, remove only the manifold seal plate, manifold cover plate, burner box cover, and manifold assembly.



Gas Conversion Instructions (cont'd)

5. Install or Remove Burner Air Restrictors - MODELS FT 250 and FT 300 ONLY (does not apply to Model SFT)

DANGER: Failure to install burner air restrictors according to directions could cause property damage, personal injury and/or death.

5A. Install Burner Air Restrictors - Applies ONLY to MODELS FT 250 and FT 300 being converted from Natural TO Propane (See Figure 4)

NOTE: This kit applies to both FT and SFT Models. **If converting a Model SFT 250 or 300 from natural to propane, do not install the burner air restrictors.** Proceed to Step 6.

- a) There are two burner air restrictors - one to be attached to the upper half of the burner assembly and one to be attached to the lower half. (The restrictors are identical; either restrictor may be attached to either half of the burner assembly.)
As shown in Figure 4, line up the two 1/4" mounting holes in one of the restrictors with the 1/8" mounting holes in the upper half of the right side of the burner assembly.
- b) Repeat, installing the other restrictor on the lower half of the burner assembly.
- c) When installed properly, the half-circle holes will be aligned with the burner orifices, and approximately one-half of the burner air opening will be restricted.

5B. Remove Burner Air Restrictors - Applies ONLY to MODELS FT 250 and FT 300 being converted from Propane TO Natural (See Figure 4)

NOTE: This kit applies to both FT and SFT Models. **If converting a Model SFT 250 or 300, there are no burner restrictors to remove.** Proceed to Step 6.

- a) There are two burner air restrictors - one attached to the upper half of the burner assembly and one attached to the lower half.
- b) Remove both air restrictors.

MODEL FT 250 AND 300 ONLY

Figure 4 - Step 5, Install Burner Air Restrictors on MODEL FT 250 and 300 being converted for use with propane gas; Remove Burner Air Restrictors on MODEL FT 250 and 300 being converted for use with natural gas

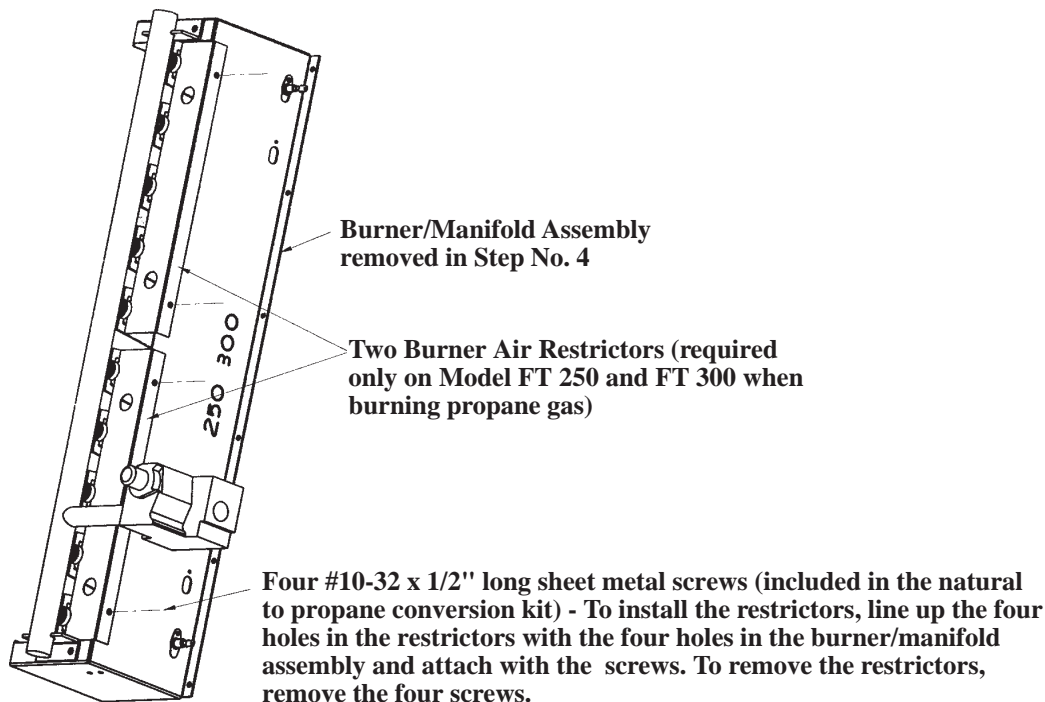

6. Re-Assemble the Heater

Reverse the procedure in Step 4 to re-assemble the heater. Be certain that the manifold and burner rack are positioned properly.

On a Model SFT, be sure that the grommet on the manifold is positioned to seal the opening in the burner box. Re-attach both the manifold cover plate and the manifold seal plate.

Attach the conversion disk to the heater near the gas valve.

7. Turn on the electric and the gas. Relight, following the instructions on the heater. Check for gas leaks using a commercial leak detecting fluid or a rich soap and water solution. Leaks are indicated by the presence of bubbles. Check all connections which were worked on during the conversion. If a leak cannot be stopped by tightening, replace the part.

8. **Adjust the manifold pressure.** Follow these requirements and instructions to adjust manifold gas pressure.

- 1) The correct pressure adjustment depends on the area of the country in terms of elevation. If you don't know the elevation, check with your local gas company.
- 2) Determine the required manifold pressure for that elevation.

Manifold Pressure Settings by Elevation

Elevation Ranges		Natural Gas (inches W.C.)	Propane Gas (inches W.C.)
Feet	Meters		
0- 2000	1-610	3.5	10.0
2001-3000	911-915	2.8	7.7
3001-4000	916-1220	2.5	7.1
4001-5000	1221-1525	2.3	6.4
5001-6000	1526-1830	2.1	5.8
6001-7000	1831-2135	1.9	5.2
7001-8000	2136-2440	1.7	4.6
8001-9000	2441-2745	1.5	4.1

- 3) With the manual valve positioned to prevent flow to the main burners, connect a manometer to the 1/8" pipe outlet pressure tap in the valve. Use a water column manometer that is readable to the nearest tenth of an inch. NOTE: A manometer (fluid-filled gauge) is recommended rather than a spring type gauge due to the difficulty of maintaining calibration of a spring type gauge.
- 4) Remove the cap from the pressure adjusting screw and adjust the manifold pressure to the pressure selected from the table above. Cycle the main burners once or twice to properly seat the adjustment spring in the valve.
- 5) Measure the manifold pressure. If adjustment is necessary, correct pressure setting by turning the regulator screw IN (clockwise) to increase pressure. Turn regulator screw OUT (counterclockwise) to decrease pressure. When the pressure is correct, remove the manometer and replace the cap. Check for leaks at the pressure tap fitting.

WARNING: Manifold gas pressure must never exceed 3.5" w.c. for natural gas or 10" w.c. for propane gas.

- 6) With the heater operating, determine that the inlet pressure to the heater is between 5 and 13.5 inches w.c. for natural gas or between 10 and 13.5 inches w.c. for propane gas. Take this reading as close as possible to the heater. (Most heaters are equipped with gas valves that have an inlet pressure tap.) If the inlet pressure is not within the specified range, the inlet pressure must be corrected and the manifold pressure re-checked.

- 7) If the gas valve has been adjusted for operation above 2000 ft, find the high altitude manifold pressure label in the kit. Using a permanent marker, fill-in the pressure setting and adhere the label to the heater in a conspicuous location close to the gas valve.

9. Check for safe and proper operation of the heater by operating the heater for at least one cycle. Observe main burners for complete flame carryover.

WARNING: Wait at least five minutes before attempting to relight the heater in the event of improper ignition.

10. Complete the information required on the gas conversion tape and affix the tape to the heater near the rating plate. Close the access door.

Conversion Kit Components - Natural to Propane

All kits include the quantity of orifices required for the largest size of heater. Excess burner orifices or unused burner restrictors may not be returned for credit.

Natural TO Propane Conversion Kit, P/N 179315		
Applies to Models FT 30, 45, 60, 75 and SFT 45, 60, 75		
Components:		
Qty	P/N	Description
1	148058	Regulator Spring Conversion Kit, Robertshaw #A54300
1	98720	Regulator Spring Conversion Kit, Honeywell #393691
5	63922	Burner Orifice, 1.15mm
1	179180	Manifold Pressure Label (High Altitude)
1	64391	Conversion Tape
1	37752	Propane Gas Disk
CK 179315		

Natural TO Propane Conversion Kit, P/N 179327			
Applies to Models FT 250 and SFT 250			
Components:			
Qty	P/N	Description	
1	98720	Regulator Spring Conversion Kit, Honeywell #393691	
8	96344	Burner Orifice, 1.65mm	
2	151002	Burner Air Restrictor	FT only
4	113275	Sheet Metal Screws, #10-32 x 1/2" long	
1	179180	Manifold Pressure Label (High Altitude)	
1	64391	Conversion Tape	
1	37752	Propane Gas Disk	
CK 179327			

Natural TO Propane Conversion Kit, P/N 179317		
Applies to Models FT 100, 125, 200 and SFT 100, 125, 200		
Components:		
Qty	P/N	Description
1	98720	Regulator Spring Conversion Kit, Honeywell #393691
1	148058	Regulator Spring Conversion Kit, Robertshaw #A54300
10	11830	Burner Orifice, #55
1	179180	Manifold Pressure Label (High Altitude)
1	64391	Conversion Tape
1	37752	Propane Gas Disk
CK 179317		

Natural TO Propane Conversion Kit, P/N 179328			
Applies to Models FT 300 and SFT 300			
Components:			
Qty	P/N	Description	
1	98720	Regulator Spring Conversion Kit, Honeywell #393691	
10	51284	Burner Orifice, #52	
2	151002	Burner Air Restrictor	FT only
4	113275	Sheet Metal Screws, #10-32 x 1/2" long	
1	179180	Manifold Pressure Label (High Altitude)	
1	64391	Conversion Tape	
1	37752	Propane Gas Disk	
CK 179328			

Natural TO Propane Conversion Kit, P/N 179318		
Applies to Models FT 150 and SFT 150		
Components:		
Qty	P/N	Description
1	98720	Regulator Spring Conversion Kit, Honeywell #393691
1	148058	Regulator Spring Conversion Kit, Robertshaw #A54300
8	64676	Burner Orifice, 1.3 mm
1	179180	Manifold Pressure Label (High Altitude)
1	64391	Conversion Tape
1	37752	Propane Gas Disk
CK 179318		

Conversion Kit Components - Propane to Natural

All kits include the quantity of orifices required for the largest size of heater. Excess burner orifices may not be returned for credit.

Propane TO Natural Conversion Kit, P/N 179316		
Applies to Models FT 30, 45, 60, 75 and SFT 45, 60, 75		
Components:		
Qty	P/N	Description
1	148059	Regulator Spring Conversion Kit, Robertshaw #A54301
1	98721	Regulator Spring Conversion Kit, Honey well #394588
5	40414	Burner Orifice, #48
1	179180	Manifold Pressure Label (High Altitude)
1	64391	Conversion Tape
1	1401	Natural Gas Disk
CK 179316		

Propane TO Natural Conversion Kit, P/N 179319		
Applies to Models FT 100, 125, 200 and SFT 100, 125, 200		
Components:		
Qty	P/N	Description
1	98721	Regulator Spring Conversion Kit, Honey well #394588
1	148059	Regulator Spring Conversion Kit, Robertshaw #A54301
1	179180	Manifold Pressure Label (High Altitude)
10	11833	Burner Orifice, #44
1	64391	Conversion Tape
1	1401	Natural Gas Disk
CK 179319		

Propane TO Natural Conversion Kit, P/N 179320		
Applies to Models FT 150 and SFT 150		
Components:		
Qty	P/N	Description
1	98721	Regulator Spring Conversion Kit, Honey well #394588
1	148059	Regulator Spring Conversion Kit, Robertshaw #A54301
8	38678	Burner Orifice, #45
1	179180	Manifold Pressure Label (High Altitude)
1	64391	Conversion Tape
1	1401	Natural Gas Disk
CK 179320		

Propane TO Natural Conversion Kit, P/N 151180		
Applies to Models FT 250, 300 and SFT 250, 300		
Components:		
Qty	P/N	Description
1	98721	Regulator Spring Conversion Kit, Honey well #394588
10	97362	Burner Orifice, #36
1	179180	Manifold Pressure Label (High Altitude)
1	64391	Conversion Tape
1	1401	Natural Gas Disk
CK 151180		

Thomas & Betts

©2000 Thomas & Betts Corporation, All rights reserved.

Printed in the U.S.A.

MANUFACTURER OF GAS, OIL, ELECTRIC HEATING AND VENTILATING SYSTEMS

4/00 7M YL8588 Form 432/433-GC (Version D)